

Engine Xinchai
A498BPG / 3.17 L
Fuel Type Diesel
Capacity @ 500 mm LC 3,000 kg

CPCD30 DIESEL PNEUMATIC TIRE FORKLIFTS



TOUGH WORLD. TOUGH EQUIPMENT.

CPCD30 SPECIFICATIONS >>>

General	Model	1			CPCD30	
	Power Type	2			Diesel	
	Base Capacity	3	@rated load center	kg	3,000	
	Load Center	4		mm	500	
Weights	Service Weight	5	unloaded	kg	4,230	
	Axle Load	6	loaded / unloaded, front	kg	6,400/1,650	
		7	loaded / unloaded, rear	kg	830/2,580	
Tires	Tire Type	8			Pneumatic	
	Wheels	9	front / rear		2/2	
	Wheelbase	10		mm	1,700	
	Tire Size	11	front			28x9-15-14PR
		12	rear			6.50-10-10PR
13	Tread Width	front / rear			1,000/980	
Mast	Max. Fork Height	14	with std 2-stage mast	mm	3,000	
	Free lift	15	with std 2-stage mast	mm	145	
	Height, Upright Lowered	16	with std 2-stage mast	mm	2,080	
	Height, Upright Extended	17	with std 2-stage mast	mm	4,146	
	Mast Tilt, Fwd/Back	18	with std 2-stage mast	deg	6° /12°	
	Carriage	19	width	mm	1,100	
	Fork Spread	20	minimum / maximum	mm	272/1,072	
	Fork Dimensions	21	T x W x L	mm	45x122x1,070	
Chassis	Length to Fork Face	22	with std 2-stage mast	mm	2,705	
	Overall Width	23		mm	1,225	
	Overhead Guard Height	24		mm	2,170	
	Turning Radius	25	minimum outside	mm	2,400	
	Fork Overhang	26	with std 2-stage mast	mm	471	
	Right Angle Stack	27	add load length and clearance	mm	4,141	
	Ground Clearance	28	minimum loaded	mm	135	
		29	center of wheelbase	mm	140	
Performance	Travel Speed	30	loaded / unloaded	km/h	18.5/19	
	Lift Speed	31	loaded / unloaded	m/s	0.455/0.475	
	Lower Speed	32	loaded / unloaded	m/s	0.46/0.48	
	Max. Drawbar Pull	33	loaded	kg	2000	
	Max. Gradeability	34	loaded / unloaded	%	20/20	
Systems	Brakes	35	service		Foot/Hyd	
		36	parking		Hand/Mech	
		37	manufacturer		Xinchai	
	Engine	38	model			A498BPG
		39	emission compliance			CHN Stage II
		40	cylinders			4
		41	displacement	liters		3.17
		42	rated power	kW/rpm		45/2,500
		43	Max. torque	N · m/rpm		193/1,800

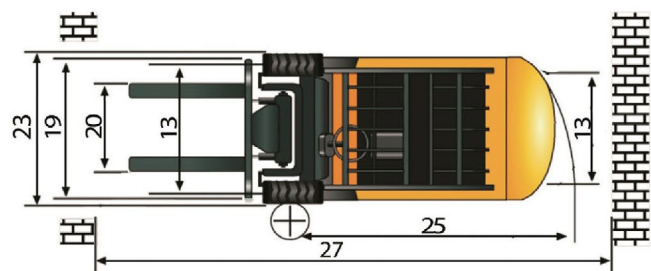
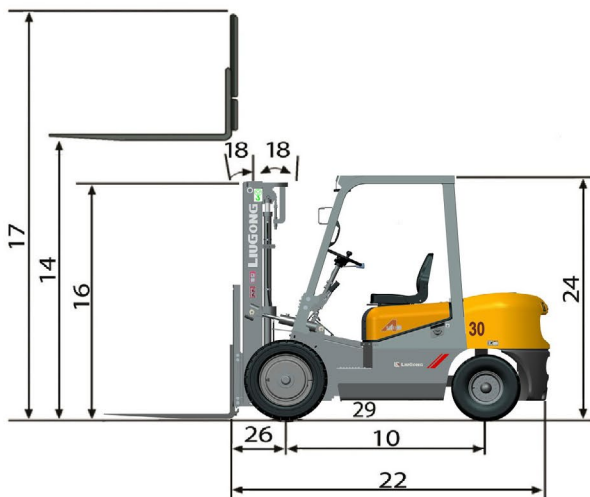

Guangxi Liugong Machinery Co., Ltd.

No. 1 Liutai Road, Liuzhou, Guangxi 545007, PR China
T: +86 772 3886124 E: overseas@liugong.com
www.liugong.com

08/2019 Designed by LiuGong

Specifications and designs are subject to change without notice. Machines shown may include optional equipment.