

# FY12S

# LOVOL

ROLLER  
SERIES

ENGINE MODEL	WP6G140E22
GROSS POWER	105kW @ 2200rpm
OPERATING WEIGHT	12000kg



# FY12S TECHNICAL PARAMETERS

## ROLLER SERIES

# LOVOL

ENGINE	FY12S	FY12S-p
Model	Weichai WP6G140E22	
Number of Cylinders	6	
Type	4-cycle, Direct Injection, Water-cooled	
Aspiration	Turbocharged	
Bore x Stroke	105*130mm	
Displacement	6.75L	
Gross Power	105kw @ 2200rpm	
Max. Torque	560N.m @ 1400~1600rpm	
Rated Fuel Consumption	210g/kW.h	
Air Cleaner	2-stage, Dry Type	
POWER TRAIN	FY12S	FY12S-p
Type	Hydrostatic, All-wheel Drive	
Driving Pump	Mechanical Control, Variable Piston Pump 75ml/r	
Axle Drive	Variable Piston Motor, 105ml/r	
Drum Drive	Constant Piston Motor, 55ml/r	
Hydraulic Relief Pressure	35MPa	
Tire	23.1-26-8PR/20.5-25-16PR	
Max. Grade Ability	48%	
Forward, I, II	0~5.3km/h, 0~9.9km/h	
Reverse, I, II	0~5.3km/h, 0~9.9km/h	
STEERING	FY12S	FY12S-p
Type	Hydraulic Power, Articulated Steering	
Hydraulic Relief Pressure	14MPa	
Steering Angle	±35°	
Oscillating Angle	±12°	
Min. Turning Radius	5500mm	
BRAKES	FY12S	FY12S-p
Service Brake	Hydraulic Inertia Brake	
Parking Brake	Multi-disc Brake, Hydraulic Control	
Emergency Brake	Hydraulic Inertia Brake & Multi-disc Brake	
DRUM	FY12S	FY12S-p
Width	2130mm	2130mm
Diameter	1500mm	1702mm
Drum Shell Thickness	28mm	28mm
Number of Pad Feet	-	132
Height of Pad Feet	-	95mm
VIBRATION	FY12S	FY12S-p
Type	Hydrostatic, Electric Control	
Vibration Pump	Variable Piston Pump, 55ml/r	
Vibration Motor	Constant Piston Motor, 55ml/r	
Hydraulic Relief Pressure	30MPa	
Frequency, Low	30Hz	30Hz
Frequency, High	35Hz	35Hz
Amplitude, High	2mm	1.7mm
Amplitude, Low	1mm	0.85mm
Centrifugal Force, Maximum	290kN	290kN
Centrifugal Force, Minimum	200kN	200kN

CAPACITIES	FY12S	FY12S-p
Fuel Tank	180L	
Hydraulic Oil Tank	80L	
Engine Coolant	30L	
Engine Crank Case	19L	
ELECTRICAL SYSTEM	FY12S	FY12S-p
Battery	2x12V, 105Ah	
Alternator	28V, 70A	
Starter Motor	24V, 6kW	
WEIGHT	FY12S	FY12S-p
Operating Weight	12000kg	13150kg
Axle Load, Drum	7000kg	8150kg
Axle Load, Wheel	5000kg	5000kg
Static Linear Load(at Drum)	327N/cm	381N/cm

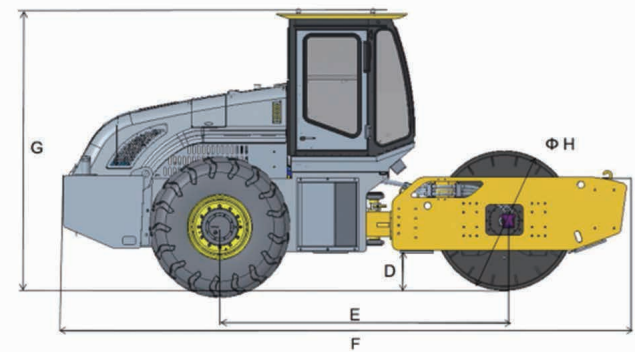
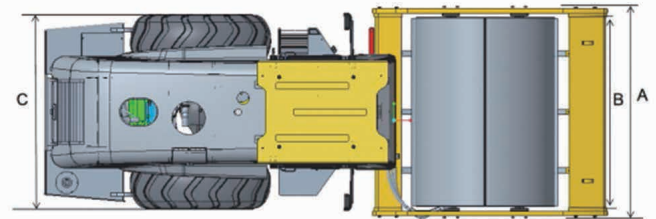

DIMENSIONS	CAB	CANOPY
A	2315mm	2315mm
B	2130mm	2130mm
C	2307mm	2307mm
D	426mm	426mm
E	3172mm	3172mm
F	5934mm	5934mm
G	3124mm	3124mm
H	1500mm	1500mm