

# FR770HD Excavators Specifications

## FR770HD Dimensions

### HIGH EFFICIENCY

- Equipped with Weichai WP15H 566kw engine and Linde 300cc main pump.
- Standard bucket capacity 4.4-5.0 CBM, Hydraulic breaker and other attachments are optional.

### MORE RELIABLE

- With original core components and stronger structure , the unit is more reliable.
- High tech level H series engine, the unit is more powerful and less LCC.

### COMFORTABLE

- Spacious and ergonomic design with excellent vision makes the operator more comfortable.
- Ergonomic joystick makes the operation more easier and fast.

### EASY MAINTENANCE

- The maintenance points are centrally distributed for easy overhauling and convenient daily maintenance.
- The remote lubrication points distributed centrally on the movable arm transport the grease to hard-to-reach locations

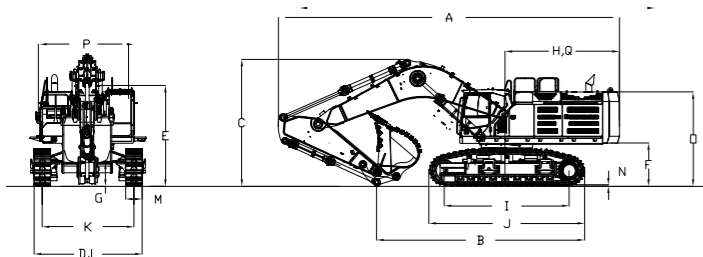

### Parameter size

Shipping Length	mm	A	12550
Shipping Ground Length	mm	B	7900
Boom Height	mm	C	4750
Shipping Width	mm	D	4250
Cab Height	mm	E	3600
Ground Clearance of Counter weight	mm	F	1580
Min. Ground Clearance	mm	G	880
Tail Turning Radius	mm	H	4180
Wheel Tread	mm	I	4570
Track Length	mm	J	5700
Track Gauge	mm	K	2830/3350
Chassis Width	mm	L	3440/3980
Track Shoe Width	mm	M	800
Rotary Platform Width	mm	P	3350
Max. Digging Height	mm	1	11300
Max. Dumping Height	mm	2	7240
Max. Digging Depth	mm	3	4250
Max. Vertical Digging Depth	mm	4	7170
Max. Digging Radius	mm	5	11760
Max. Ground Digging Radius	mm	6	11380
Min. Turning Radius	mm	7	5100
Boom Length	mm		6800
Arm Length	mm		2800

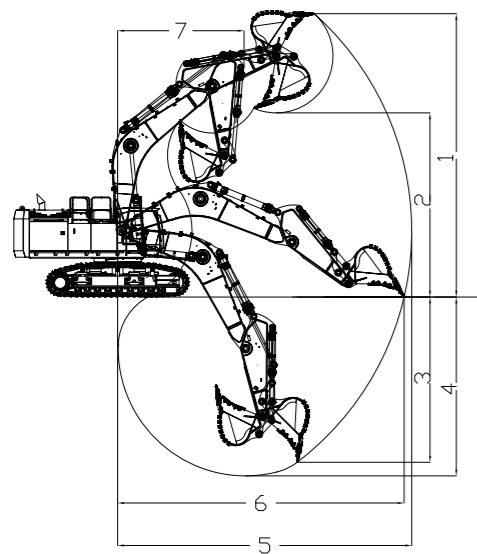

# LOVOL



## LOVOL HEAVY INDUSTRY GROUP CO.,LTD.

Address: No. 75, Huanghe East Road, Huangdao District, Qingdao City, Shandong Province, China.  
 Website: [en.wlovol.com](http://en.wlovol.com)    Alibaba: [lovolconstruction.en.alibaba.com](http://lovolconstruction.en.alibaba.com)    Facebook: Cons Lovol  
 E-mail: [lovol\\_overseas@global.lovol.com](mailto:lovol_overseas@global.lovol.com)    TEL: +86-532-86907190

As manufacturer, LOVOL has right to constantly upgrade and improve our products without informing to customers.  
 The pictures in literatures are for reference only, the detailed specifications are subject to real products.

Engine Model	<b>WEICHAI WP15H</b>
Rated Power	<b>566KW/1900rpm</b>
Operating Weight	<b>69000KG</b>
Bucket Capacity	<b>5.0M<sup>3</sup></b>

# FR770HD

EXCAVATORS