



**BF90.3: the legendary model, ideal for excavators with weight ranging from 20 tons.**



Perfect for on-site crushing of inert materials and the first one of its kind to be introduced on the market, the MB Crusher Bucket is a piece of equipment that works by taking advantage of the hydraulic system of the excavators to which it is fitted.

It has many areas of applications: from building demolitions in general, to the requalification of former industrial and urban areas to the processing of excavation materials, from the earth movement sector to road works, from quarries to mines, from environmental reclamation to applications on rocky soil.

Its versatility of use and advantages have led to the very high production levels of the MB bucket: directly on site, the bucket crushes any type of material excluding iron, and allows the product that requires crushing to be collected by placing it in a mound on the truck or in the site to be filled in, thus hastening operations.

MB Crusher Buckets lead to a significant reduction in management costs and in the recycling of inert material without going through landfill, a fundamental factor in terms of respect for the environment and savings on disposal costs.

**The MB crusher bucket can be operated either with single-acting hydraulic system (hammer) and with the double effect (clamp).**

There are also specific accessories available to implement the performance of the Crusher Bucket: **the mechanical or hydraulic universal quick coupler** and the exclusive **iron separator** that allows to easily separate iron elements.

- **MB, THE ONLY CRUSHER BUCKET OWNER OF THE PATENT FOR DOUBLE JAW MOVEMENT**, to ensure high productivity and resistance in all types of sites.
- **MB, THE ONLY COMPACT AND VERSATILE CRUSHER BUCKET** which allows for better balance on the excavator, drastically reducing the effort of the arm.



## APPLICATION FIELDS

- DEMOLITIONS
- ROADS CONSTRUCTION
- EXCAVATIONS
- QUARRIES AND MINES
- ENVIRONMENTAL  
REMEDIATIONS
- VINEYARD DEEP-PLOWING
- RECYCLING

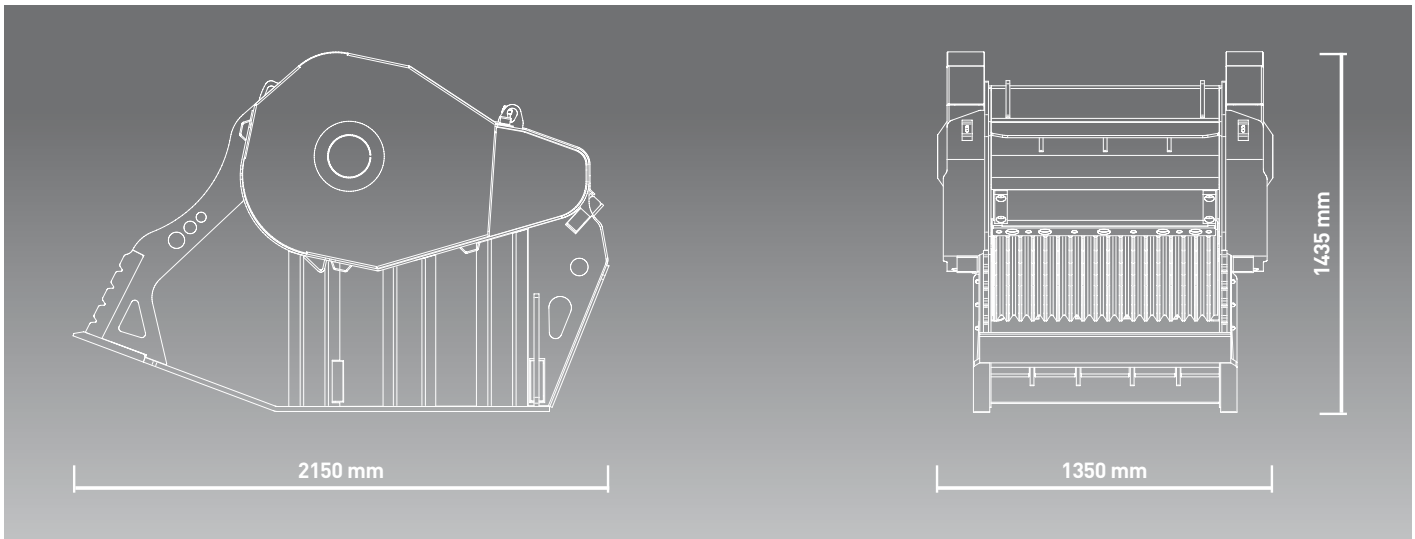

RECOMMENDED EXCAVATOR	LOAD CAPACITY	BUCKET LOADING OPENING	CRUSHER OUTPUT ADJUSTMENT	DIMENSIONS
≥ 20 Ton	0,80 m <sup>3</sup>	L 900 H 510 mm	≥ 15 mm ≤ 120 mm	135 x 215 H 143,5 cm

OIL FLOW RATE (min/max)	PRESSURE	BACKPRESSURE	WEIGHT	MAXIMUM PRODUCTION*
180 (litri/1')	230 bar	10 bar	3,5 Ton	40,0 m <sup>3</sup> /h - 60,00 Ton/h

\*Values ton/h calculated considering an estimated weight of material 1.5 Ton/m<sup>3</sup> on medium tenacity material under optimal conditions

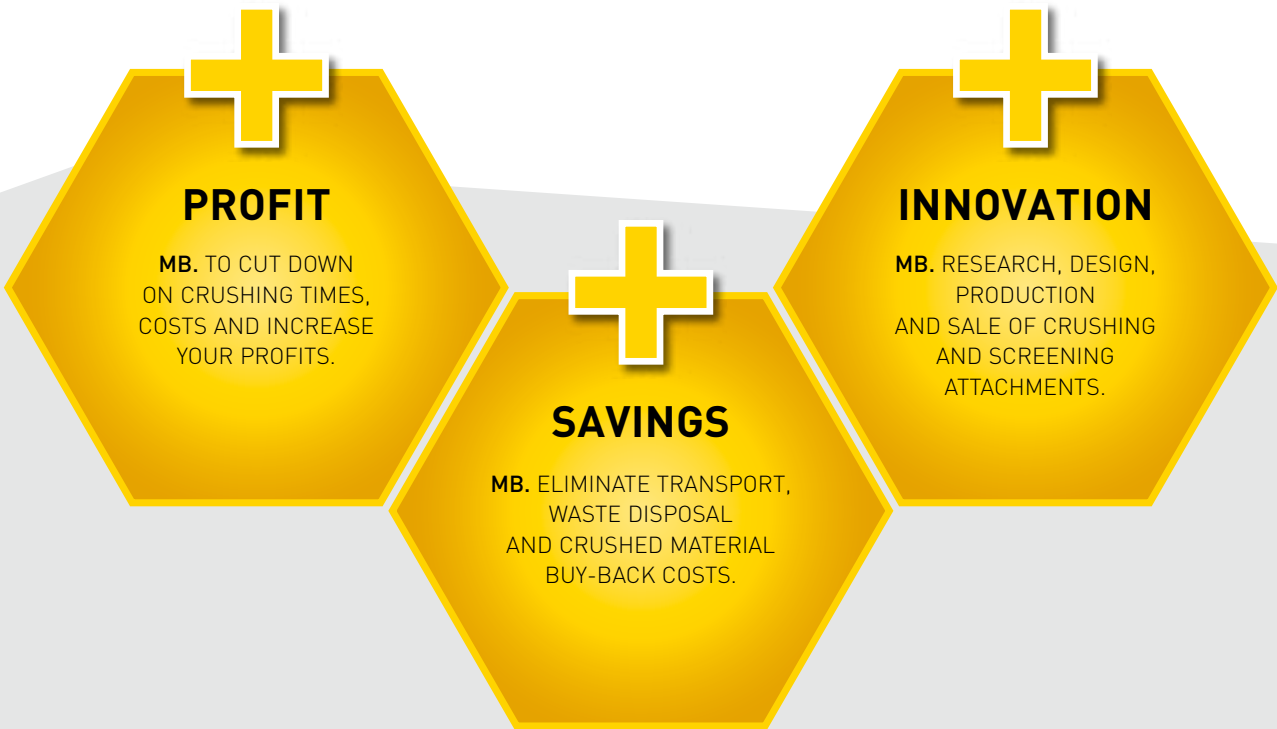

COMPANY WITH QUALITY MANAGEMENT SYSTEM CERTIFIED BY DNV = ISO 9001:2008 =  
Certified head office: Fara Vicentino



COMPANY CERTIFICATION UNI EN ISO 14001:2004 IN PROGRESS

