

**Engine** Xinchai  
C490BPG / 2.67 L  
**Fuel Type** Diesel  
**Capacity @ 500 mm LC** 2,000 kg

# CPCD20 DIESEL PNEUMATIC TIRE FORKLIFTS



TOUGH WORLD. TOUGH EQUIPMENT.

# CPCD20 SPECIFICATIONS >>>

<b>General</b>	<b>Model</b>	1			CPCD20	
	<b>Power Type</b>	2			Diesel	
	<b>Base Capacity</b>	3	@rated load center	kg	2,000	
	<b>Load Center</b>	4		mm	500	
<b>Weights</b>	<b>Service Weight</b>	5	unloaded	kg	3,355	
	<b>Axle Load</b>	6	loaded / unloaded, front	kg	4,685/1,345	
		7	loaded / unloaded, rear	kg	670/2,010	
<b>Tires</b>	<b>Tire Type</b>	8			Pneumatic	
	<b>Wheels</b>	9	front / rear		2/2	
	<b>Wheelbase</b>	10		mm	1,650	
	<b>Tire Size</b>	11	front		7.00-12-12PR	
		12	rear		6.00-9-10PR	
13	Tread Width	front / rear		960/970		
<b>Mast</b>	<b>Max. Fork Height</b>	14	with std 2-stage mast	mm	3,000	
	<b>Free lift</b>	15	with std 2-stage mast	mm	140	
	<b>Height, Upright Lowered</b>	16	with std 2-stage mast	mm	2,070	
	<b>Height, Upright Extended</b>	17	with std 2-stage mast	mm	4,025	
	<b>Mast Tilt, Fwd/Back</b>	18	with std 2-stage mast	deg	6° /12°	
	<b>Carriage</b>	19	width	mm	1,100	
	<b>Fork Spread</b>	20	minimum / maximum	mm	272/1,072	
	<b>Fork Dimensions</b>	21	T x W x L	mm	40x100x1,070	
<b>Chassis</b>	<b>Length to Fork Face</b>	22	with std 2-stage mast	mm	2,590	
	<b>Overall Width</b>	23		mm	1,150	
	<b>Overhead Guard Height</b>	24		mm	2,100	
	<b>Turning Radius</b>	25	minimum outside	mm	2,190	
	<b>Fork Overhang</b>	26	with std 2-stage mast	mm	458	
	<b>Right Angle Stack</b>	27	add load length and clearance	mm	3,935	
	<b>Ground Clearance</b>	28	minimum loaded	mm	110	
		29	center of wheelbase	mm	120	
		30				
<b>Performance</b>	<b>Travel Speed</b>	30	loaded / unloaded	km/h	19/20	
	<b>Lift Speed</b>	31	loaded / unloaded	m/s	0.53/0.55	
	<b>Lower Speed</b>	32	loaded / unloaded	m/s	0.42/0.51	
	<b>Max. Drawbar Pull</b>	33	loaded	kg	1,680	
	<b>Max. Gradeability</b>	34	loaded / unloaded	%	18/20	
<b>Systems</b>	<b>Brakes</b>	35	service		Foot/Hyd	
		36	parking		Hand/Mech	
		37	manufacturer		Xinchai	
	<b>Engine</b>	38	model			C490BPG
		39	emission compliance			CHN Stage II
		40	cylinders			4
		41	displacement	liters		2.67
		42	rated power	kW/rpm		40/2650
		43	Max. torque	N · m/rpm		160/1800

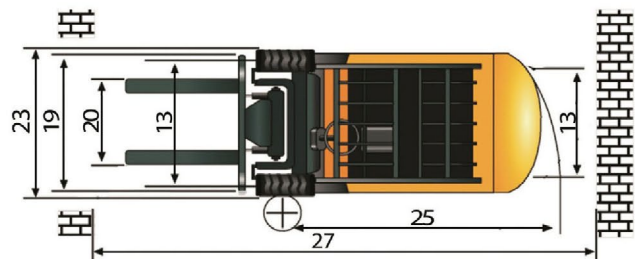
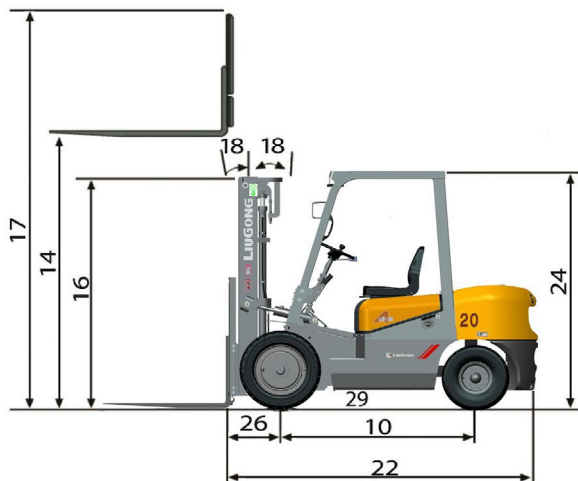

Guangxi Liugong Machinery Co., Ltd.

No. 1 Liutai Road, Liuzhou, Guangxi 545007, PR China  
T: +86 772 3886124 E: overseas@liugong.com  
www.liugong.com

08/2019 Designed by LiuGong

Specifications and designs are subject to change without notice. Machines shown may include optional equipment.